



UPB Universal Dimming Transceiver Base Model US2-40

Provides ON/OFF and dimming control for:

- Incandescent lighting
- Magnetic low-voltage lighting
- Halogen lighting

IMPORTANT!
Read This Before Installing!

- **This incandescent dimmer cannot be used to dim FLUORESCENT, ELECTRONIC LOW-VOLTAGE or METAL HALIDE lighting, unless specifically allowed by the lighting manufacturer. Please see instructions to configure this product for ON/OFF operation with these types of lighting.**
- **DO NOT WIRE HOT!** Permanent damage may result. Improper installation voids the warranty.

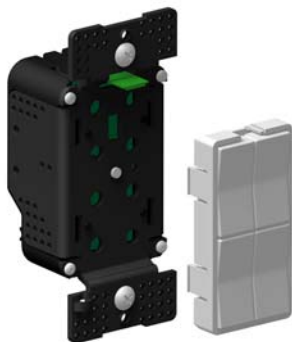

Model US2-40 shown with actuator faceplate (sold separately)

FUNCTION

The SimplyBrilliant™ UPB Universal Dimming Transceiver Base, model US2-40, provides direct load control and/or remote control of permanently-installed new or existing lighting fixtures, lamps and other electrical devices connected to UPB devices. Incandescent lamps can be turned ON or OFF, and can also be dimmed and brightened. The US2-40 can be configured to turn other types of non-dimmable loads ON and OFF. Actuator faceplates, model series ZS1X and ZS2X, available in rocker and/or pushbutton styles, are fully interchangeable on the US2-40 base. The US2-40 can be configured to control a load and provide scene control, or scene control only (no load). The US2-40 can control a load of up to 900W (see table 1). Load control can be configured to any rocker or button on the various actuator faceplates. All switch actuators may act as transmitters that can communicate with other UPB devices, either individually or collectively for lighting scenes.

IMPORTANT SAFETY INSTRUCTIONS

When using electrical products, basic safety precautions should always be followed, including the following:

1. READ AND FOLLOW ALL SAFETY INSTRUCTIONS.
2. Installation should be performed by a qualified electrician.
3. Keep away from water. If product comes into contact with water or other liquid, disconnect immediately.
4. Never use products that have been dropped or damaged.
5. Do not use this product outdoors.
6. Do not use this product for other than its intended use.
7. Do not connect multiple lamps that, when combined, exceed the maximum load rating of the product, de-rated for multi-gang boxes.
8. Do not install in areas that can exceed 120°F (e.g., in an attic).
9. To avoid the risk of overheating and possible damage to other equipment, do not use this product to control a receptacle.
10. Do not cover the product with any material when in use.
11. SAVE THESE INSTRUCTIONS.

INSTALLATION

The SimplyBrilliant™ UPB Universal Dimming Transceiver Base (US2-40) is designed to be installed in a junction box that is wired to a readily accessible over-current protection device in the building wiring per NEC and CEC electrical codes.

CAUTION: The default switch configuration operates as a dimmer for incandescent lamps. It will also dim magnetic low-voltage and halogen lamps. To control fluorescent, electronic low-voltage or metal halide lamps, or motor-operated appliances, transformer-supplied appliances or fans, the switch must be reconfigured for ON/OFF operation (no dimming) prior to use. Refer to the section on Configuration.

CAUTION: DO NOT WIRE THIS DEVICE WITH POWER CONNECTED. Injury or permanent damage to the device may result. Improper installation voids the product warranty.

1. Locate the existing wall switch for the lighting to be controlled. Note that the lamp rating (or the combined rating of all connected lamps) must not exceed what is shown in the de-rating table below.

Table 1: Power per Dimmer		Number of Load Dimmers in J-box		
		1	2	3+
Number of J-box Gangs	1	600W	--	--
	2	800W	500W	--
	3+	900W	700W	500W

2. Disconnect power at the circuit breaker.
3. Remove the existing wall switch hardware. Disconnect the wires to the switch.
4. Remove the yellow "INSTALL WITH CARE" label on the US2-40 if present.
5. Using a wire nut, connect all white (Neutral) wires together.
6. Using a wire nut, connect the brown (load output) wire of the US2-40 to the black wire of the device to be controlled.
7. IF THIS IS TO BE A 3- OR MORE-WAY INSTALLATION, use a wire nut to connect the brown/white "REMOTE 1" wire or red/white "REMOTE 2" wire if there is a second 3-way switch traveler. Refer to the wiring diagrams on pages 3 and 4.
8. Using a wire nut, connect the black (Line) wire of the US2-40 switch to the black (Line) power wire.
9. Mount the switch inside the J-box using captive screws. DO NOT OVER TIGHTEN THE SCREWS.
10. Reconnect power at the circuit breaker.



CONFIGURATION

Configuration requires UPB setup/configuration software and a model UMC Computer Interface Module. Before using UPStart configuration software, be sure to download the latest version from the Simply Automated website. First time users should also download and follow the Quick Start Guide and use the Installation Wizard available in UPStart to save time.

The US2-40 default settings are preconfigured for a ZS24 (quad rocker) faceplate. The default settings ensure the load will operate locally with any faceplate. To utilize essential functions, the UPB settings should be configured by the installer for the specific faceplate. Any rocker or button can be configured to control the local load. When using UPStart, this is done by selecting the faceplate "device type" when adding the device to the network.

SETUP MODE

When configuring a UPB system, it is often necessary to place the US2 in SETUP mode in order to initiate self-identification on the powerline. To place the US2 in SETUP mode, tap any rocker/pushbutton exactly 5 times consecutively. The LED indicator will continuously blink GREEN when the unit is in SETUP mode. Module will stay in SETUP mode for five minutes. Once the US2-40 has been added to the powerline network, UPStart will put the US2 back into Normal mode. To EXIT SETUP mode manually, and enter NORMAL mode, tap any rocker/pushbutton twice.

OPERATION

Unless otherwise configured, rocker actuators behave as follows:

Rocker Event	Dimmer Action	
	Top Rocker	Bottom Rocker
Single-Tap	Brighten to 100% at Default Rate	Fade to 0% at Default Rate
Double-Tap	Snap to 100%	Snap to 0%
Hold	Start brightening to 100% at Default Rate	Start fading to 0% at Default Rate
Release	Stop brightening and hold current level	Stop fading and hold current level

The US2 is configured from the factory to accept a single rocker, or a multi-rocker faceplate, where the top-left (#1) rocker provides ON/OFF and dimming control functions for the connected light fixture (local load). However, the local load may be assigned to ANY rocker or button using a link which must be present in both the transmit and receive tables accessible via UPStart.

The factory default for local load control is 'Link 241' with the transmit options disabled. Additional rockers / buttons function as transmitters to other UPB devices. Local load may be included in any scene using the link feature in UPStart. See illustration at right for actuator numbering examples.



- By linking a switch to a (non-dimming) UPB Receptacle, Appliance Module or Fixture Relay Module, the connected load can be turned ON by tapping the top rocker and OFF by tapping the bottom rocker. Pushbuttons can be configured to toggle the load ON and OFF, or single-tap ON and double-tap OFF. Fan motors and water pumps are usually controlled with ON/OFF switching instead of dimming.
- By linking a transmitting switch to a (dimming) UPB Lamp or Fixture Dimmer Module, the connected load can be controlled according to the table above. Pushbuttons can be configured as a "Super Toggler," which will alternate the dimmer actions of a top and bottom rocker.

Local response time adjustments are available (300, 450, 600 and the default 750 mSec) and configured with UPStart configuration software. Local response time is the time from rocker press to load response.

POWER DISCONNECTION

To disconnect power to the connected lamp fixture, depress the top of the rocker switch, grab the underside of the clear plastic indicator tab with your fingernail, pull the tab out about 0.2" until it stays in place. The LED indicator will extinguish to show that power is now disconnected. To reconnect power, simply push the tab back into its normal position.

OVERLOAD PROTECTION

The US2-40 contains a thermal sensor that automatically turns off the connected load if the switch becomes too hot. This can occur when the load exceeds the power rating of the switch, or when dimming incompatible loads or if the switch is in an environment that exceeds the maximum operating temperature (120°F). If the load begins to turn OFF and ON repeatedly without command or actuation, then the load must be reduced.

INSTALLING/CHANGING FACEPLATES

SimplyBrilliant Dimming Wall Switches are designed with removable actuator faceplates, making it possible to upgrade functionality and/or change color in the field without disconnecting the switch from the wall. Changing faceplate types will require re-configuration via UPStart.

To install a faceplate assembly, do the following:

- Hold the actuator faceplate assembly so that clear plastic light pipe (LED) on the switch fits nicely into the recess on the top of the faceplate.
- Align the four prongs on the side of the faceplate assembly with the four slots on the switch body.
- While squeezing the prongs on both sides, press the faceplate into the switch body. Ensure that all four prongs are fully inserted and latched into the switch body. If all four prongs are not fully latched, the rocker/button plungers may not function properly.
- Exercise each rocker/button several times to ensure proper seating and operation. If the rocker or button doesn't operate properly, remove and re-install the faceplate to check proper seating and operation.

To remove the faceplate assembly to upgrade functionality or to change color, do the following:

- Remove the wall plate from the switch.
- Using the thumb and index finger, press the top two prongs of the rocker faceplate assembly inward so that they unlatch from the switch body. This will release the top of the rocker assembly.
- Press the two lower prongs inward, and pull the faceplate assembly away and slightly downward from the switch body, moving it away from the clear plastic light pipe.
- Once the old faceplate is removed, follow steps 1-4 above for instructions on installing a new rocker faceplate assembly.

To change faceplate labeling, do the following:

- Remove the clear plastic label cover on the oval or thin-bar button faceplate.
- Flip label over to hide switch numbers, or
- If custom labels are preferred, order the custom label kit, (Model ZLK-01, specify color) to print your own labels.

Universal Dimming Transceiver Base

Model US2-40

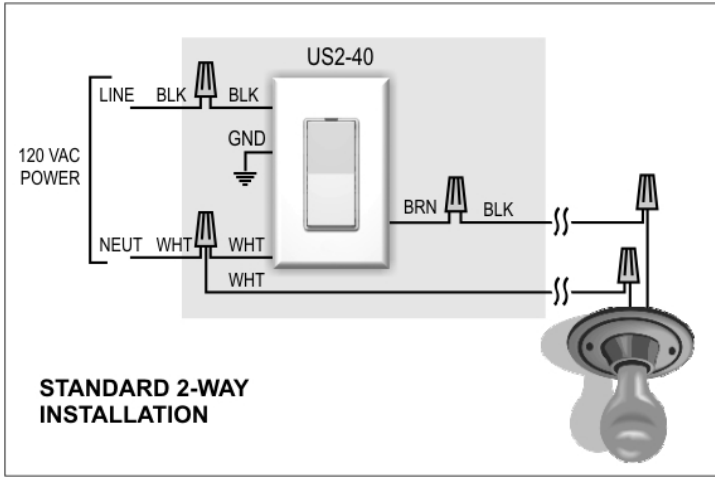

WIRING OPTIONS

- A: US2-40 + USR
- B: US2-40 + USR-40

NOTES:

** Cap any unused BRN/WHT or RED/WHT wires to avoid shorting.

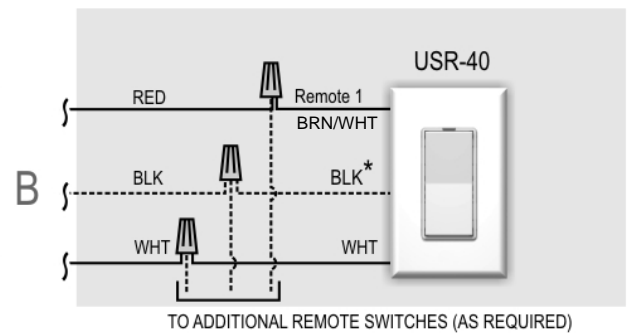
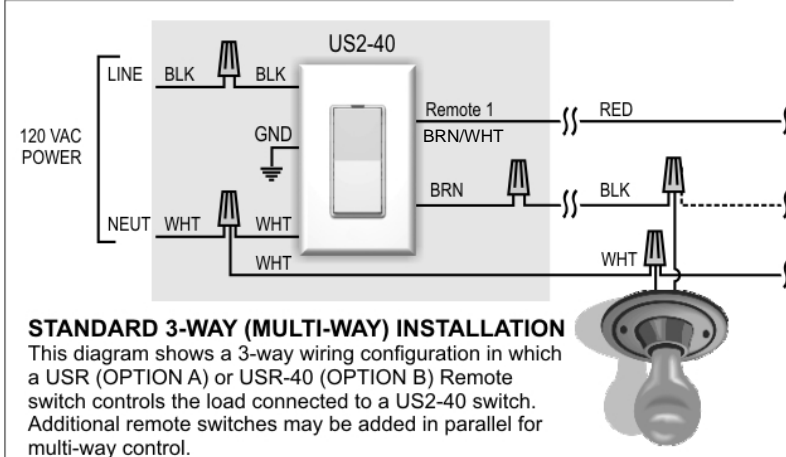
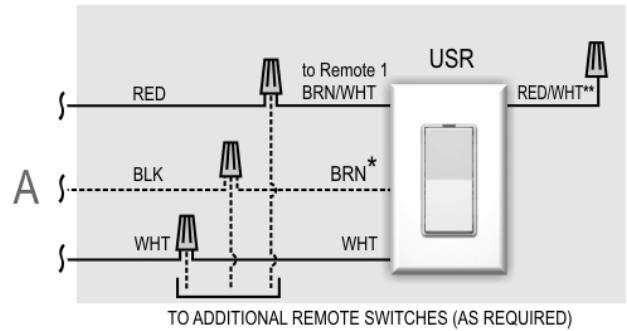

NOTES:

* CONNECT THE BLACK WIRE OF THE USR-40 (BROWN ON USR) AS SHOWN TO ENABLE OPERATION OF THE LED INDICATOR. THIS WIRE IS NOT REQUIRED FOR SWITCH OPERATION AND CAN BE OMITTED IF A THIRD WIRE IS NOT AVAILABLE.

3-WAY (MULTI-WAY) INSTALLATION FOR A MULTI-ROCKER SWITCH

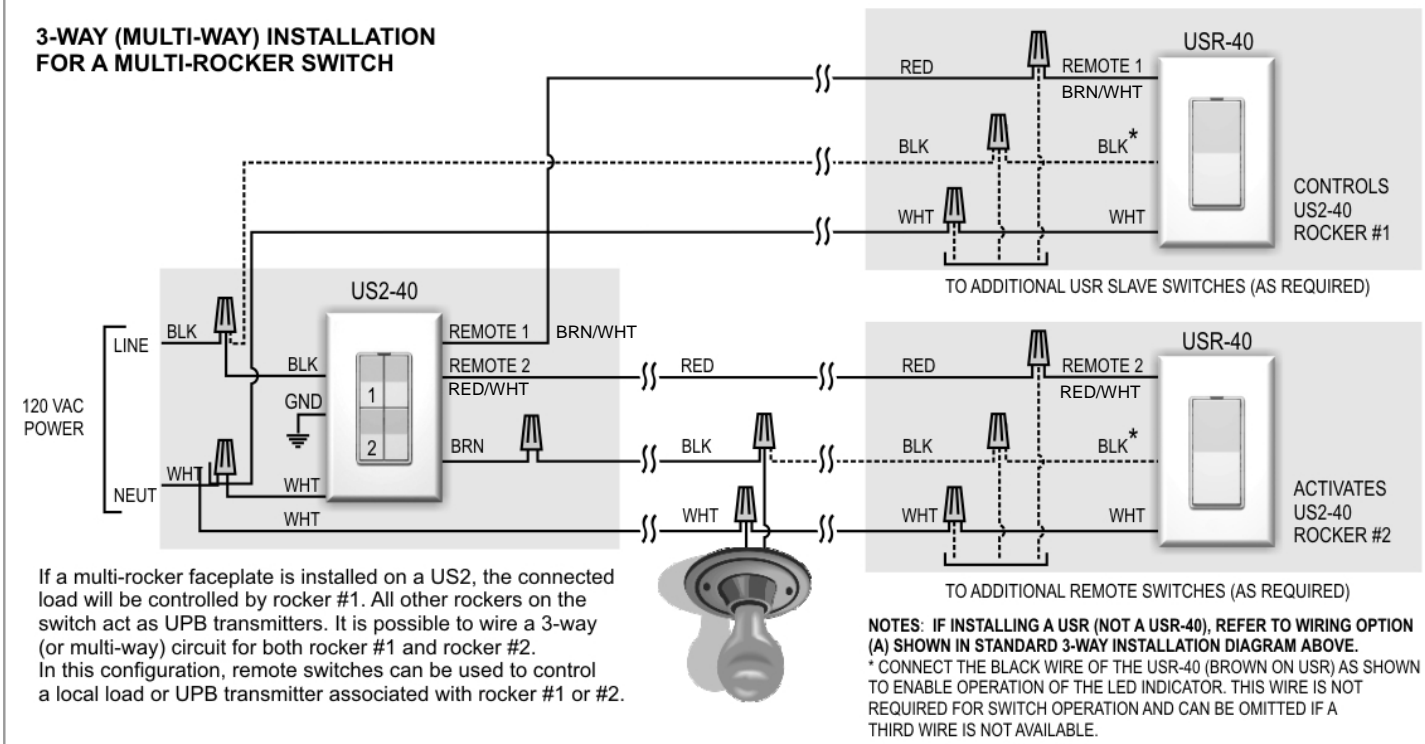

DUAL-ROCKER 3-WAY (MULTI-WAY) INSTALLATION

If a multi-rocker faceplate is installed on a US2-40, by default from the factory, the connected load will be controlled by the top-left rocker. All other rockers on the switch act as UPB transmitters. If a dual-rocker faceplate is installed on a USR, it is possible to wire a 3-way (multi-way) circuit such that the top-left rocker (or buttons 1 & 2 on a two-button) and bottom-left rocker (or buttons 3 & 4) of the US2-40 will connect with the two rockers on the USR.

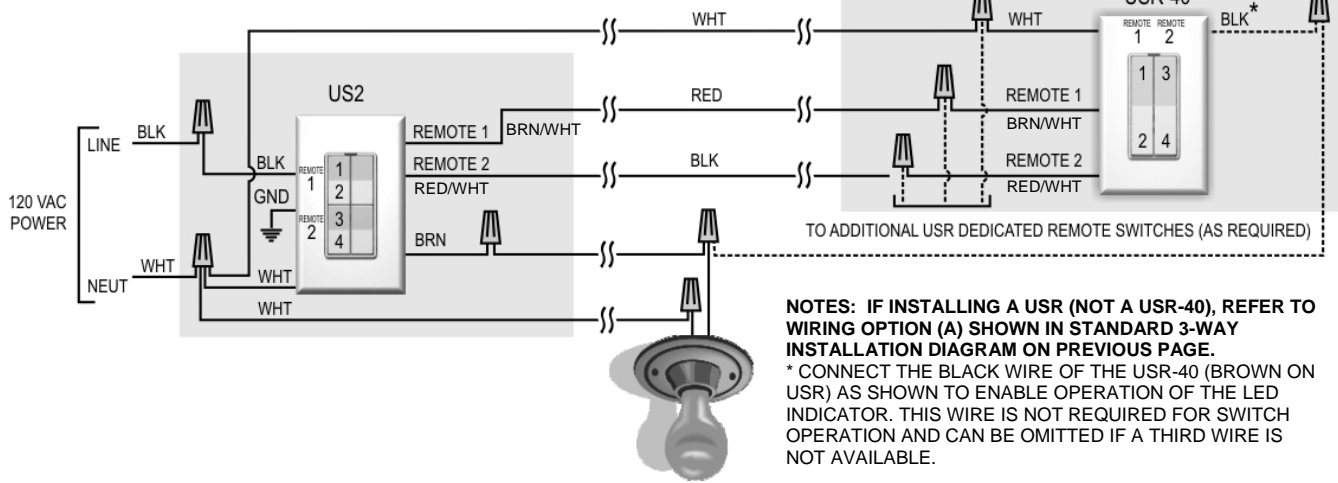

NOTES: IF INSTALLING A USR (NOT A USR-40), REFER TO WIRING OPTION (A) SHOWN IN STANDARD 3-WAY INSTALLATION DIAGRAM ON PREVIOUS PAGE.
 * CONNECT THE BLACK WIRE OF THE USR-40 (BROWN ON USR) AS SHOWN TO ENABLE OPERATION OF THE LED INDICATOR. THIS WIRE IS NOT REQUIRED FOR SWITCH OPERATION AND CAN BE OMITTED IF A THIRD WIRE IS NOT AVAILABLE.

TROUBLESHOOTING

PROBLEM	PROBABLE CAUSE	SOLUTION
Master switch is wired properly but has no power (e.g. LED indicator is OFF).	Air gap power disconnect may be disengaged (pulled out).	Push light pipe (LED indicator) back into position flush with faceplate assembly housing.
		Test buttons without faceplate with appropriately-sized non-metallic object such as a toothpick or golf tee
Master switch actuator doesn't turn load ON and/or OFF (e.g. LED indicator is ON).	3-way remote switch actuator may be binding, causing the switch to be stuck ON or OFF.	Loosen mounting screws on remote switch and/or wallplate to relieve pressure on housing.
	Actuator faceplate may not be seated properly on the switch body.	Exercise actuator several times to ensure proper seating and operation. If necessary, remove and replace faceplate to ensure proper seating and operation.
	Switch faceplate may be incorrectly selected in UPStart	Select the correct faceplate in UPStart
Buttons and/or rockers stick or don't actuate properly when pressed.	Mounting screws may be too tight or j-box may be deformed, causing the switch body to warp.	Loosen mounting screws to relieve pressure on the switch housing.
	Actuator faceplate may not be seated properly on the switch body.	Exercise actuator several times to ensure proper seating and operation. If necessary, remove and replace faceplate to ensure proper seating and operation.
Load turns ON and OFF regularly without actuation or command.	Switch is overloaded.	Reduce the power load by removing bulbs from the circuit.
	Switch is dimming a load that is not rated for use with incandescent dimmers.	Reconfigure the switch for ON/OFF operation with no dimming (using UPStart, for example).
Switched links to other UPB devices are intermittent.	Linked UPB devices are on other phase of the homes' 2 phase power.	Install a phase coupler at each breaker panel. Perform UPStart 'Communications Test' to measure signal strength and presence of noise.

UPB FACTORY DEFAULT SETTINGS

To restore the following default settings, place the US2 in SETUP mode and tap any actuator exactly 10 times. The indicator will continuously blink BLUE. Tap the actuator twice again to exit SETUP mode.

Network Name	"Network 1"	
Room Name	"New Room Name"	
Device Name	"New SA US2-40"	
Unit ID	29	
Network ID	255	
Network Password	1234	
Rocker 1 Top	Transmit Link	241 (internal)
Rocker 1 Bottom	Transmit Link	241 (internal)
Rocker 2 Top	Transmit Link	11 (internal)
Rocker 2 Bottom	Transmit Link	241 (internal)
Rocker 3 Top & Bottom	Transmit Link	1
Rocker 4 Top & Bottom	Transmit Link	10
Receive Links	1 (ON), 2(OFF) and 241 (internal)	

MANUAL SCENE CREATION & MODIFICATION

Once the US2-40 has been initially configured, it is possible to make scene changes without configuration software.

- To create a scene for one of the US2-40 actuators, set all scene devices to the desired light levels and then place them in SETUP mode. Tap the scene actuator (e.g. button 1) on the US2 exactly 7 times to create the scene and store the light levels.
- To add a device to an existing scene, activate the scene and set the light level on the device to be added. Place the device in SETUP mode and tap the scene actuator on the US2 exactly 7 times to modify the scene.
- To remove a device from an existing scene, place the device to be removed in SETUP mode. Tap the scene actuator on the US2 exactly 8 times to modify the scene.
- To change light levels on an existing scene, set the levels as desired and tap the scene actuator on the US2 exactly 7 times to modify the scene.