

**Add to Anywhere 3-Way Virtual Switch Kits for 4-Way remote lighting control. Or use for virtual remote lighting and appliance control of Anywhere Virtual Remote Lighting Control Accessories: Anywhere Switch (US1-V0), controlled receptacle (URD-V0), plug-in (UMA-V0) and wire-in (UFR-V0) relay modules.**

- **ON/OFF control of local circuit, and virtual remote control of one or more Anywhere Virtual Switches and Accessories**
- **Replaces existing mechanical switch – hot and neutral connections required**
- **3-rocker switch's top rocker controls local circuit and devices set on channel 2, bottom rockers control remote switches and devices set on channel 1 & 4.**
- **Compatible with LED, incandescent, Halogen, fluorescent, low-voltage lighting and motors - pump/fan (900 W / 7.5 Amps max., 1 W min.)**
- **Vapor (Sodium/Mercury) or metal-halide lights may require isolation (model ZNF10A-W) filters.**

**IMPORTANT!**  
**Read This Before Installing!**

- **DO NOT WIRE HOT! Permanent damage may result. Improper installation voids the warranty. If necessary pull out LED indicator light-pipe (1/4 inch) to disconnect power and avoid damage.**



Anywhere Virtual Accessory Switch is shown with detachable, white-rocker faceplate. Color/rocker change kits sold separately (see model ZS22, ZS23 and ZS24).

## FUNCTION

**Model US2-V03** The Anywhere Virtual Accessory Switch for remote lighting and appliance control replaces an existing mechanical switch and use the existing switch wires (white neutral wire required) to provide virtual 3-way remote control - no traveler wires or batteries needed. The Anywhere Virtual Remote Lighting and Appliance Control Switch and Accessories offer a cost effective alternative for the professional electrician – versus running costly new wiring or using wireless 3-way consumer DIY options that do not always work. The US2-V03 remotely controls lighting and loads connected to any number of the accessories, including other Anywhere Switches (US1-V0, US2-V0 or V3WAY-A or -B), controlled receptacles (URD-V0), plug-in (UMA-V0) and wire-in (UFR-V0) relay modules. And, use Anywhere Scheduler-Timer (UCS-V0) for automatic control and expanded functionality.

The switch has a (900 Watt maximum, 1 Watt minimum) output circuit wire that can be connected to control a local light/load circuit. If only a remote light circuit needs to be controlled, simply use a wire nut (included) to cap the unused output wire. Top-rocker – pressing the top of the rocker turns on the switch output and remotes set on channel #2 (status LED shines green). Pressing the bottom of the rocker turns off the switch output and channel #2 remotes (status LED shines blue). Bottom-rockers – pressing the top/bottom of the rocker turns on/off remotes set on channel 1 (bottom-left) and 4 (bottom-right).

The top rocker controls the 900W output load wire and any number of Anywhere devices on channel #2 (e.g. another US2-V0). The bottom rockers controls any number of Anywhere devices on channels 1 (left-rocker) and 4 (right-rocker). These transmit channels are fixed, they cannot be changed. However, the faceplate can be changed from 2-rockers to a 3- or 4- rocker faceplate for control of up to 4 lighting zones (see faceplate models ZS23 and ZS24). Using the Scheduler-Timer (model UCS-V0) the US2-V0 switch and other Anywhere devices can be set to receive 4 separate channels. This allows the switch to respond to a channel that can be used as "All On/Off", and also respond to a separate channel for manual, or automatic scheduled / timed control (8 channels are available) with UCS-V0. The switch also has a thermal overload protection mechanism. It will cycle the switch off if it gets too hot, helping prevent accidental overload. An over-loaded switch will cycle off/on/off/on until the switch is turned off or the load is reduced to within specifications.

The professional grade Anywhere Virtual Accessory Switch and Anywhere Accessories for remote lighting control employ Simply Automated's advanced powerline communication technology. This technology is safe and reliable. It has no radio frequency (RF) emissions, and is used reliably in tens of thousands of homes with no adverse affects to appliances, stereo equipment, ham radios, cordless phones, wireless RF modems/devices, computer equipment or other home automation technology like the much less reliable X10. In fact the technology is employed in freeway bridge applications spanning over a mile. The Anywhere Switch US2-V0 is compatible with Simply Automated's "Anywhere" switches and accessories, including: Anywhere Switches (US1-V0 & US2-V0), controlled receptacle (URD-V0), plug-in (UMA-V0) and wire-in (UFR-V0) relay modules. 'Anywhere' switches and accessories are **not compatible (will not talk to or work) with any of Simply Automated's PC-Configured, Pre-Configured, SimplySmart™, or other UPB or UPStart configured product solutions.**

## IMPORTANT SAFETY INSTRUCTIONS

When using electrical products, basic safety precautions should always be followed, including the following:

1. READ AND FOLLOW ALL SAFETY INSTRUCTIONS.
2. Installation should be performed by a qualified electrician.
3. Keep away from water. If product comes into contact with water or other liquid, disconnect immediately.
4. Never use products that have been dropped or damaged.
5. Do not use this product outdoors (unless protected from moisture).
6. Do not use this product for other than its intended use.
7. Do not connect multiple lamps that, when combined, exceed the maximum load rating of the product, de-rated for multi-gang boxes.
8. Do not install in areas that can exceed 120°F (e.g., in an attic).
9. To avoid the risk of overheating and possible damage to other equipment, do not wire this product directly to a receptacle.
10. Do not cover the product with any material when in use.
11. SAVE THESE INSTRUCTIONS.

## INSTALLATION

The Anywhere Virtual Accessory Switch is designed to be installed in a junction box that is wired to a readily accessible over-current protection device in the building wiring per NEC and CEC electrical codes.

**CAUTION: DO NOT CONNECT TO RECEPTACLE – USE MODEL URD-V0 CONTROLLED RECEPTACLE.** The default switch configuration operates as an on/off switch; using a single tap to the top/bottom of the rocker to turn on/off.

**ATTENTION: NE PAS SE CONNECTER A RECIPIENTS.** La configuration du commutateur par défaut fonctionne comme un interrupteur marche / arrêt, à l'aide d'une simple pression vers le haut / bas de la bascule pour activer / désactiver.

**CAUTION: DO NOT WIRE THIS DEVICE WITH POWER CONNECTED.** Injury or permanent damage to the device may result. Improper installation voids the product warranty.

1. Locate the existing wall switch where the Anywhere Virtual Accessory Switch will be installed. Note that the connected lamp rating (or the combined rating of all connected lamps/loads) must not exceed what is shown in the de-rating table below.

**Table 1:**  
Power per Dimmer

		Number of US1/US2 Switches in J-box		
		1	2	3+
Number of J-box Gangs	1	600W	--	--
	2	800W	500W	--
	3+	900W	700W	500W

- Disconnect power at the circuit breaker for the switch circuit. Utilize the power 'disconnect' to prevent damage if wiring hot (see below).
- Remove the existing wall switch. Disconnect the wires to the switch.
- If a color/rocker change kit will be used to change out the faceplate, see "INSTALLING/CHANGING FACEPLATES" section for details.
- At the switch location use a wire nut to connect all white (Neutral) wires together. Make sure the connection is tight and strong to ensure good communication between switches and accessories.
- At the switch location use a wire nut to connect the brown (load output) wire of the switch to the black wire of the load/fixture to be controlled. If the switch does not need to control a local load, then cap the unused brown load wire with a wire nut.
- At the switch location use a wire nut to connect the black (Line) wire of the switch to the black (Line) power wire. Make sure the connection is tight and strong to ensure good communication between switches and accessories.
- Mount the switch inside their respective J-box using captive screws. **DO NOT OVER TIGHTEN THE SCREWS.**
- Reconnect power at the circuit breakers.
- Top-Rocker: Press and release top of the top-rocker to turn on switch and any other installed Anywhere accessories that are set on channel #2. Press and release bottom of top-rocker to turn off switch and any other installed Anywhere accessories on channel #2.
- Bottom-Rockers: Press and release top of the left or right rocker to turn on installed Anywhere accessories that are set on channel # 2 or 4, respectively. Press and release bottom of left or right rocker to turn off installed Anywhere accessories on channel # 2 or 4.

## WIRING DIAGRAM

Anywhere switch requires a hot (line) and neutral connection. The brown load wire connects to the lighting circuit (switch leg). If no lighting circuit needs to be connected at the switch then cap brown wire with a wire nut.

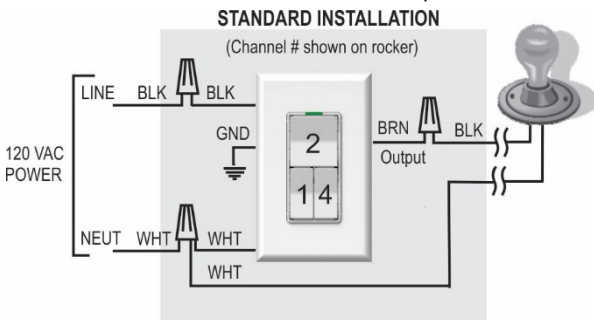

## POWER DISCONNECTION

To disconnect power to the switch and connected lamp fixture, depress the top of the rocker switch, grab the underside of the clear plastic indicator tab (light pipe) with your fingernail, and pull the tab out about 0.2" until it stays in place. The LED indicator will extinguish showing that power is now disconnected. To reconnect power, simply push the tab back into its normal position. Utilize the 'disconnect' to prevent damage if the switch must be wired hot.

## CHANGING CHANNELS

If separate lighting 'zones', or 'sets' of Anywhere Remote Lighting Controls will be used on the properties' power service, then the separate 'set' of switches and accessories will need to be configured for a channel other than #2 (US2-V0 local load). The US2-V03 rocker channels are fixed, they cannot be changed. However, there are four (4) available channels that can be used by other Anywhere devices (US1-V0, UMA-V0, UFR-V0 and URD-V0) and changing them is easy. Refer to the User Guide of the specific Anywhere device to change its channel.

## FACTORY DEFAULT SETTINGS

To restore the switch to the original factory default settings (e.g. responding to channel #2 only), tap the rocker 5 times quickly. The LED will flash green. Then tap the rocker 10 times quickly. The LED will flash blue. Tap the rocker 2 times quickly and the LED will stop flashing. At this point the switch is reset.

## INSTALLING/CHANGING FACEPLATES

Anywhere Switches are designed with removable actuator faceplates, making it possible to change color in the field without disconnecting the switch from the wall.

**To remove the faceplate assembly to change color, do the following:**

- If installed in a junction box, remove the wall plate framing the switch.
- Using the thumb and index finger, press the top two side-prongs of the rocker faceplate assembly inward so that they unlatch from the switch body. This will release the top of the rocker assembly.
- Press the two lower side-prongs inward, and pull the faceplate assembly away and slightly downward from the switch body, moving it away from the clear plastic light pipe.
- Once the faceplate is removed, follow steps 1-4 below for instructions on installing a new rocker faceplate assembly.

**To install a faceplate assembly, do the following:**

- Hold the actuator faceplate assembly so that clear plastic light pipe (LED) on the switch fits nicely into the recess on the top of the faceplate.
- Align the four prongs on the side of the faceplate assembly with the four slots on the switch body.
- While squeezing the prongs on both sides, press the faceplate straight onto the switch body. Ensure that all four prongs are fully inserted and latched into the switch body. If all four prongs are not fully latched, the rocker plungers may not function properly.
- Exercise rocker several times to ensure proper seating and operation. If the rocker doesn't operate properly, remove and re-install the faceplate to check proper seating and operation.

## TROUBLE SHOOTING

Simply Automated's Powerline technology is extremely robust. Using large low frequency pulses in a patented pulse position modulation protocol, they can overcome power line noise and capacitive attenuation in most (98%) applications. In the event that the switch and accessories are set for the same channel, but are not communicating (i.e. turning each other on/off) or controlling the local light/load circuit(s), here are steps to diagnose and resolve the issue:

- Are the LED indicators lit on both switches, indicating the switches are powered? If not, make sure the Power Disconnect (LED light pipe) is pressed in, check hot and neutral wire-nut connections and circuit breaker state.
- Do both the switches' LEDs change from blue to green when turning from off to on? If not, check hot and neutral wire-nut connections making sure the connection is tight and strong for good communication. If yes, then check the brown load wire connection to the fixtures' switch leg, and if necessary the light fixture and bulb. A volt meter or power indicator probe is helpful in confirming switch leg power vs. bulb/fixture fault.

At this step one switch should be turning the lighting circuit on/off. Or if each switch has a connected lighting circuit then each switch should be able to control its own lighting circuit. If they are not controlling each other, double check they are on the same channel (try resetting to factory default as described above). If they still don't control each other there would appear to be a communication issue, and phase alignment (swap breakers/wires so both switched are on the same phase, either phase A or B) or installing a phase coupler (model ZPCI) may be necessary. For addition trouble shooting assistance, please call or write Simply Automated Technical Support at 800-630-9234 / 760-431-2100 (Ext. 138) or [Support@Simply-Automated.com](mailto:Support@Simply-Automated.com) or see [http://www.simply-automated.com/Anywhere\\_Virtual\\_3-way\\_Applications.php](http://www.simply-automated.com/Anywhere_Virtual_3-way_Applications.php)